



**Doosan Infracore**  
Construction Equipment

# DX140LC

Engine power: 71 kW / 95 Hp at 1.850 rpm

Operational weight: 14.000 kg

Bucket capacity (SAE): 0,24 ~ 0,76 m<sup>3</sup>



DOOSAN DX140LC hydraulic excavator:

a new



**Look at these innovations !**

Performance	4
Handling	6
Comfort	7
Reliability	8
Maintenance	10
Technical Specifications	12



The DX140LC hydraulic excavator offers additional added value to the operator.

The key phrase used during the development of the DX140LC was “giving optimum value to the end user”. This translates, in concrete terms, into:

# model with novel features

- **Increased production and improved fuel economy** thanks to electronic optimization of the hydraulic system and the new generation DOOSAN engine (stage IIIa).
- **Improved ergonomics**, increased comfort and excellent all round visibility ensuring a safe and pleasant working environment.
- **Improved reliability** through the use of high performance materials combined with new methods of structural stress analysis have lead to increased component life expectancy, thus reducing running costs.
- **Reduced maintenance** increases the availability of the excavator and reduces running costs.



# Performance

The performance of the DX140LC has a direct effect on its productivity. Its new “Common Rail” engine and new e-EPOS controlled hydraulic system have combined to create an unbeatable hydraulic excavator, with a cost/performance ratio that makes the DX140LC even more appealing.



“Common Rail” Doosan DLo6 Engine

At the heart of the hydraulic excavator is the new “Common Rail” Doosan DLo6 engine. It is combined with the new e-EPOS electronic control system, for optimum power and fuel saving.

The new engine produces 95 Hp (71 kW/96 Ps) at only 1.850 rpm, and more torque, due to its careful design combined with the use of common rail injection and 4 valves per cylinder. These features help optimize combustion and minimize pollution through reduced Nox & particulate emissions.

Increased torque allows efficient use of the power of the hydraulic system.

- Faster working cycles increase productivity.
- Increased torque means the excavator is able to move more easily.
- Energy efficiency reduces fuel consumption.

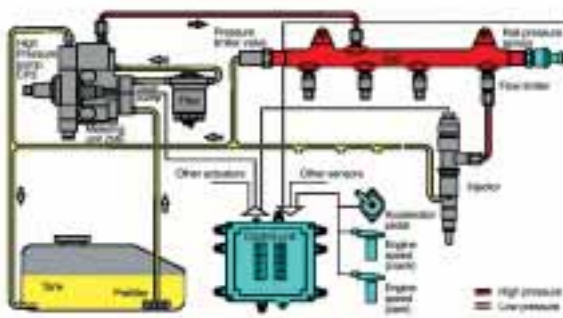

## Hydraulic pumps

The main pumps have a capacity of 2 x 114 l / min reducing cycle time while a high capacity gear pump improves pilot line efficiency.



## Excavator control

### New e-EPOS system (Electronic Power Optimizing System)

The brains of the hydraulic excavator, the e-EPOS, have been improved and now can electronically link to the engines ECU (Electronic Control Unit), through a CAN (Controller Area Network) communication link, enabling a continuous exchange of information between the engine and the hydraulic system. These units are now perfectly synchronised.

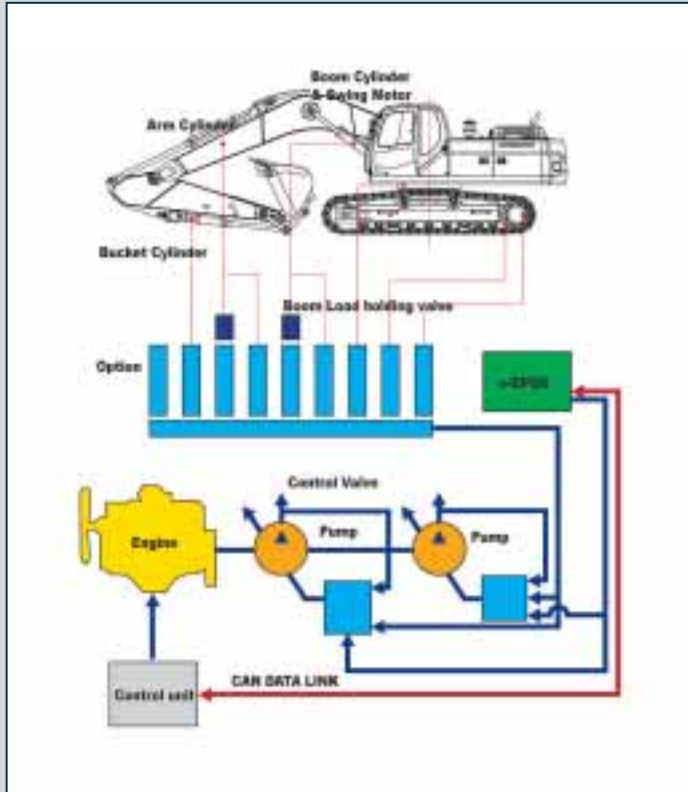

The advantages of the new e-EPOS impacts at several levels.

Ease of operation and user-friendliness:

- The availability of a power mode and a normal operating mode guarantee maximum efficiency under all conditions.
- Electronic control of fuel consumption optimizes efficiency.
- The automatic deceleration mode enables fuel saving.
- Regulation and precise control of the flow rate required by the equipment are available as standard.
- A self-diagnosis function enables technical problems to be resolved quickly and efficiently.
- An operational memory provides a graphic display of the status of the machine.
- Maintenance and oil change intervals can be displayed.

### DOOSAN Infracore is aware of the importance of protecting the environment.

Ecology was uppermost in the minds of the research workers right from the start of the design of the new machines. The new challenge for the engineers is to combine the protection of nature with equipment performance and to this end DOOSAN has been investing heavily.

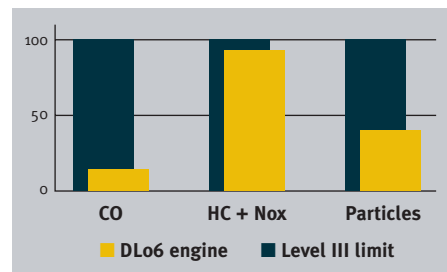

The new DOOSAN engine respects and protects the environment, limiting all types of toxic emissions.



### Dozer Blade (Optional)

The pin type design allows the dozer blade to be mounted on the front and/or rear and is used for leveling, clean-up work and for stabilizing the machine during digging applications. The large dozer bottom and parallel design provide minimized ground pressure.



### Swing drive

Shocks during rotation are minimized, while increased torque is available to ensure rapid cycles.

# Handling

The hydraulic excavator's power, durability, ease of servicing and its precise control increase its effectiveness and life expectancy. With the DX140LC, DOOSAN offers an excellent return on investment.



Multi-function colour LCD monitor panel

## Warning lights

## Operating modes

- Mode selection
- Flow rate control
- Auto deceleration
- Display selection

## Control panel

With colour LCD display



Standard screen



Anti-theft function



Filter/oil information

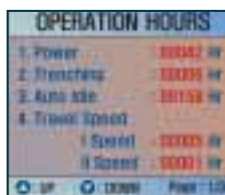

Operation history



Flow rate control



Contrast control

## Choice of operating modes

### Work mode

- Digging mode: for general excavation, loading, lifting...
- Trenching mode: swing priority for trench work, canal digging, embankments...

### Power mode

- Standard: uses 85% engine power for all work (optimum fuel efficiency)
- Power: uses 100% engine power for heavy work



## Control lever

Very precise control of the equipment increases versatility, safety and facilitates tricky operations requiring great precision. Levelling operations and the movement of lifted loads in particular are made easier and safer.

The control levers have additional electrical buttons for controlling other additional equipment (for example, grabs, crushers, grippers, etc.).

# Comfort

The work rate of the hydraulic excavator is directly linked to the performance of its operator. DOOSAN designed the DX140LC by putting the operator at the centre of the development goals. The result is significant ergonomic value that improves the efficiency and safety of the operator.

More space, better visibility, air conditioning, a very comfortable seat... These are all elements that ensure that the operator can work for hours and hours in excellent conditions.



## Control panel

Correct positioning with clear controls makes the operator's task easier.



The high performance air conditioning provides an air flow which is adjusted and electronically controlled for the conditions. Five operating modes enable even the most demanding operator to be satisfied.



Visibility has been improved in all directions and the size of the cab has been increased.



Independently adjustable control module height



Comfortable fully adjustable seat



Appropriate storage spaces show the attention given to the operator.



## Air suspension seat (optional)

An air suspension seat is available as an option, which further reduces any vibration being transmitted to the operator while working or travelling. In addition, this option is fitted with a heating system for operator comfort in cold weather.



## Dozer control (optional)

The Dozer Control Lever is positional above the left-hand control stand to secure easy and convenient access.

# Reliability

The reliability of an item of plant contributes to its overall lifetime operating costs. DOOSAN uses computer-assisted design techniques, highly durable materials and structures then test these under extreme conditions.

**Durability of materials and longevity of structures are our first priorities.**

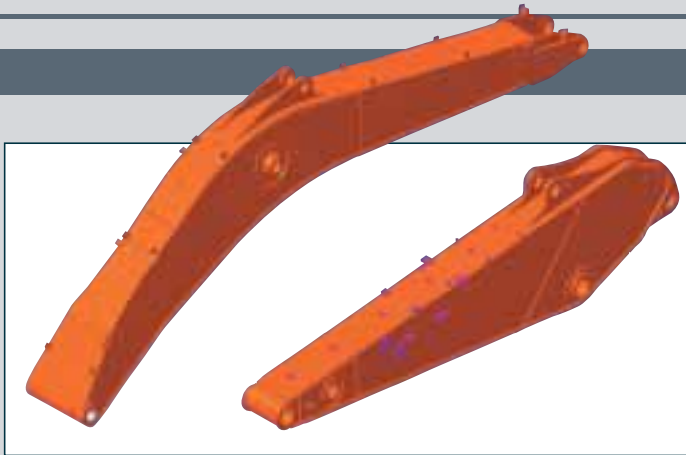

## Strengthened boom

The shape of the boom has been optimized by finite elements design, allowing the loads to be better distributed throughout the structure. This combined with increased material thickness means improved durability and reliability by limiting element fatigue.

## Arm assembly

In the arm assembly greater strength has been gained by using cast elements and reinforcement around the bosses to give it an increased lifetime.



## Bucket

Highly wear-resistant materials are used for the most susceptible elements such as the blades, teeth, rear and lateral reinforcement plates and corners of the bucket.



## Bushing

A highly lubricated metal is used for the boom pivot in order to increase the lifetime and extend the greasing intervals to 250 hours. A rolled bushing with very fine grooves has been added to the arm to bucket pivot, so that greasing is only required every 50 hours.



## Ultra hard wear-resistant discs

New materials have been used in order to increase the wear resistance and to increase the service intervals. The longevity is greatly increased by the addition of wear plates on the inside and the outside of the bucket lugs.



## X-chassis

The X-chassis frame section has been designed using finite element and 3-dimensional computer simulation, to ensure greater durability and optimum structural integrity. The swing gear is solid and stable.

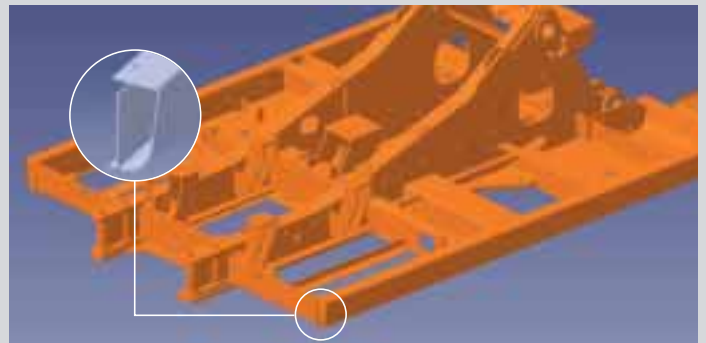

## D-type frame

The D-type frame and chassis frame add strength and minimize distortion due to shocks.





#### Tracks

The chain is composed of self-lubricating sealed links isolated from all external contamination. The tracks are locked by mechanically bolted pins.



#### Polymer shim

A polymer shim is added to the bucket pivot to maintain precise control over the equipment.



#### Integrated Track Spring and Idler

The track spring and the idler have been joined directly to achieve high durability and improved maintenance convenience.

# Maintenance

Short maintenance operations at long intervals increase the availability of the equipment on site. DOOSAN has developed the DX140LC with a view to high profitability for the user.



## Engine oil filter

The engine oil filter offers a high level of filtration allowing the oil change interval to be increased to 500 hours. It is easy to access and is positioned to avoid contaminating the surrounding environment.



## Easy maintenance

Access to the various radiators is very easy, making cleaning easier. Access to the various parts of the engine is from the top and via side panels.



## Hydraulic oil return filter

The protection of the hydraulic system is made more effective by the use of glass fibre filter technology in the main oil return filter. This means that with more than 99,5% of foreign particles filtered out, the oil change interval is increased.



## Air cleaner

The large capacity forced air cleaner removes over 99% of airborne particles, reducing the risk of engine contamination and making the cleaning and cartridge change intervals greater.



## Fuel filter

High efficiency fuel filtration is attained by the use of multiple filters, including a fuel filter fitted with a water separator that removes most moisture from the fuel.

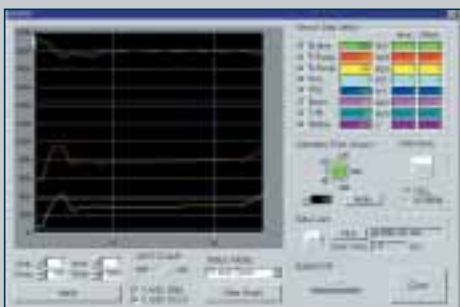

## PC monitoring

A PC monitoring function enables connection to the e-EPOS system, allowing various parameters to be checked during maintenance, such as pump pressures, engine rotation speed, etc, and these can be stored and printed for subsequent analysis.



## Centralized grease inlets for easy maintenance

The arm grease inlets are grouped for easy access.



# Technical specifications

**DX 140LC**

## \* Engine

### • Model

DOOSAN DLo6  
 “Common Rail” engine with direct fuel injection and electronic control, 4 valves per cylinder, vertical injectors, water cooled, turbo charged with air to air intercooler.  
 The emission levels are well below the values required for Phase III.

### • Number of cylinders

6

### • Nominal flywheel power

71 kW (96 Ps) at 1.850 rpm (DIN 6271 net)  
 71 kW (95 Hp) at 1.850 rpm (SAE J1349 net)

### • Max torque

44,5 kgf.m (446 Nm) at 1.400 rpm

### • Piston displacement

5.890 cc

### • Bore & stroke

100 mm x 125 mm

### • Starter

24 V / 4,5 kW

### • Batteries

2 x 12 V / 100 Ah

### • Air cleaner

Double element with auto dust evacuation

## \* Hydraulic system

The heart of the system is the e-EPOS (Electronic Power Optimizing System). It allows the efficiency of the system to be optimized for all working conditions and minimizes fuel consumption.

The new e-EPOS is connected to the engine electronic control via a data transfer link to harmonize the operation of the engine and hydraulics.

- The hydraulic system enables independent or combined operations.
- Two travel speeds offer either increased torque or high speed tracking.
- Cross-sensing pump system for fuel savings.
- Auto deceleration system.
- Two operating modes, two power modes.
- Button control of flow in auxiliary equipment circuits.
- Computer-aided pump power control.

### • Main pumps

2 variable displacement axial piston pumps  
 Max flow: 2 x 114 l/min

### • Pilot pump

Gear pump – max flow: 27,75 l/min

### • Main relief valves

Boom/arm/bucket:  
 Normal mode: 330 kg/cm<sup>2</sup> (324 bar)  
 Power mode: 350 kg/cm<sup>2</sup> (343 bar)  
 Travel: 330 kg/cm<sup>2</sup> (324 bar)  
 Rotation: 245 kg/cm<sup>2</sup> (240 bar)

## \* Weight

Boom 4.600 mm • Arm 2.500 mm • Bucket 0,51 m<sup>3</sup> (SAE)

	Shoe width (mm)	Operating weight (kg)	Ground pressure (kg/cm <sup>2</sup> )
Triple grouser	500	13.800	0,43
	600 (std)	14.000	0,36
	700	14.200	0,30

## \* Weight with Dozer Blade

Std- : Boom 4.600 mm • Arm 2.500 mm • Bucket 0,51 m<sup>3</sup> (SAE)

	Shoe width (mm)	Dozer blade weight	Operating weight (kg)
Triple grouser	STD + 500 mm	2.500 mm : 590 kg	14.770
	STD + 600 mm	2.600 mm : 602 kg	15.007
	STD + 700 mm	2.700 mm : 615 kg	15.245

## \* Hydraulic cylinders

The piston rods and cylinder bodies are made of high-strength steel. A shock absorbing mechanism is fitted in all cylinders to ensure shock-free operation and extend piston life.

Cylinders	Quantity	Bore x Rod diameter x stroke
Boom	2	110 x 75 x 1.085 mm
Arm	1	115 x 80 x 1.108 mm
Bucket	1	100 x 70 x 900 mm

## \* Undercarriage

Chassis are of very robust construction, all welded structures are designed to limit stresses.  
High-quality material used for durability.  
Lateral chassis welded and rigidly attached to the undercarriage.  
Track rollers lubricated for life, idlers and sprockets fitted with floating seals.  
Tracks shoes made of induction-hardened alloy with triple grousers.  
Heat-treated connecting pins.  
Hydraulic track adjuster with shock-absorbing tension mechanism.

### • Number of rollers and track shoes per side

Upper rollers:	1
Lower rollers:	7
Shoes:	46
Total length of track:	3.755 mm

## \* Environment

Noise levels comply with environmental regulations (dynamic values).

### • Sound level guarantee

101 dB(A) (2000/14/EC)

### • Cab sound level

71 dB(A) (ISO 6396)

## \* Swing mechanism

- An axial piston motor with two-stage planetary reduction gear is used for the swing.
- Increased swing torque reduces swing time.
- Internal induction-hardened gear.
- Internal gear and pinion immersed in lubricant bath.
- The swing brake for parking is activated by spring and released hydraulically.

Swing speed: 0 to 10,7 rpm

## \* Drive

Each track is driven by an independent axial piston motor through a planetary reduction gearbox.  
Two levers with control pedals guarantee smooth travel with counter-rotation on demand.

### • Travel speed (fast/slow)

4,7 / 3 km/h

### • Maximum traction force

7.300 / 11.800 kgf

### • Maximum grade

35° / 70 %

## \* Refill capacities

### • Fuel tank

280 l

### • Cooling system (Radiator capacity)

20 l

### • Engine oil

25 l

### • Swing drive

3,8 l

### • Final drive

3 l (each)

### • Hydraulic tank

150 l

## \* Buckets

Capacity (m <sup>3</sup> )	Width (mm)		Weight (Kg)	Recommended arm (mm)				
	Without side cutters	With side cutters		4.600 mm one-piece boom			4.988 mm two-piece boom	
SAE				2.100	2.500	3.000	2.100	2.500
0,24	468	534	270	A	A	A	A	A
0,39	736	820	330	A	A	B	A	B
0,45	824	911	365	A	B	B	B	B
0,51	907	991	380	A	B	C	B	C
0,59	997	1081	400	B	C	-	C	-
0,64	1038	1167	425	C	-	-	C	-
0,76	1255	1339	475	C	-	-	C	-

A. Suitable for materials with a density less than or equal to 2,000 kg/m<sup>3</sup>

B. Suitable for materials with a density less than or equal to 1,600 kg/m<sup>3</sup>

C. Suitable for materials with a density less than or equal to 1,100 kg/m<sup>3</sup>

# Dimensions and working ranges

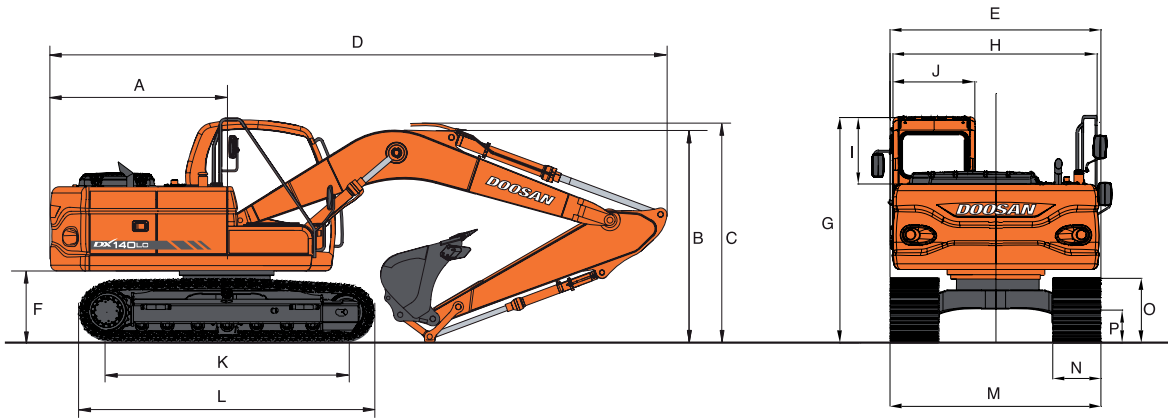

Dimensions – Boom: 4.600 mm - Arm: 2.500 mm - Shoe: 600 mm - Std.

## \* Dimensions

	one-piece boom	two-piece boom
H Overall width of upper structure	2.540 mm	2.540 mm
J Overall width of cabin	960 mm	960 mm
G Overall height of cabin	2.773 mm	2.773 mm
A Tail swing radius	2.200 mm	2.200 mm
C Overall height	2,1 m	2.570 mm
	2,5 m (std)	2.710 mm
	3,0 m	3.090 mm
F Clearance under counterweight	894 mm	894 mm
P Ground clearance	410 mm	410 mm
K Tumbler distance	3.034 mm	3.034 mm
L Track length	3.755 mm	3.755 mm
N Track shoe width	600 mm	600 mm
D Overall length	2,1 m	7.690 mm
	2,5 m (std)	7.680 mm
	3,0 m	7.640 mm
M Overall width	2.590 mm	2.590 mm

## \* Digging forces (ISO)

Arm	2,1 m	2,5 m	3,0 m
Bucket digging force*	11.100 kgf 109 kN	11.100 kgf 109 kN	11.100 kgf 109 kN
Arm digging force*	7.700 kgf 76 kN	6.500 kgf 64 kN	6.000 kgf 59 kN

\* Max. force

## \* Working range

Boom length	4.600 mm (one-piece)			4.980 mm (two-piece)	
	2.100 mm	2.500 mm	3.000 mm	2.100 mm	2.500 mm
Arm length					
Type of bucket (PCSA)	0,51 m <sup>3</sup>	0,51 m <sup>3</sup>	0,39 m <sup>3</sup>	0,51 m <sup>3</sup>	0,51 m <sup>3</sup>
A. Max. digging reach	mm	7.845	8.300	8.680	8.380
B. Max. digging reach at ground level	mm	7.690	8.156	8.540	8.235
C. Max. digging depth	mm	5.250	5.645	6.150	5.440
D. Max. dumping height	mm	5.875	6.300	6.415	6.420
E. Min. dumping height	mm	2.569	2.166	1.700	2.925
F. Max. digging height	mm	8.195	8.675	8.745	8.820
G. Max. bucket pin height	mm	7.110	7.535	7.645	7.650
H. Max. vertical wall height	mm	3.810	4.560	4.830	4.815
I. Max. vertical radius	mm	5.690	5.555	5.860	5.365
J. Max. digging depth (8° level)	mm	4.950	5.420	5.920	5.530
K. Min. radius 8° line	mm	1.850	1.960	1.855	795
L. Min. digging reach	mm	1.005	265	-305	2.000
M. Min. swing radius	mm	2.345	2.375	2.585	2.925
d. Bucket angle (deg)	°	173	173	173	173

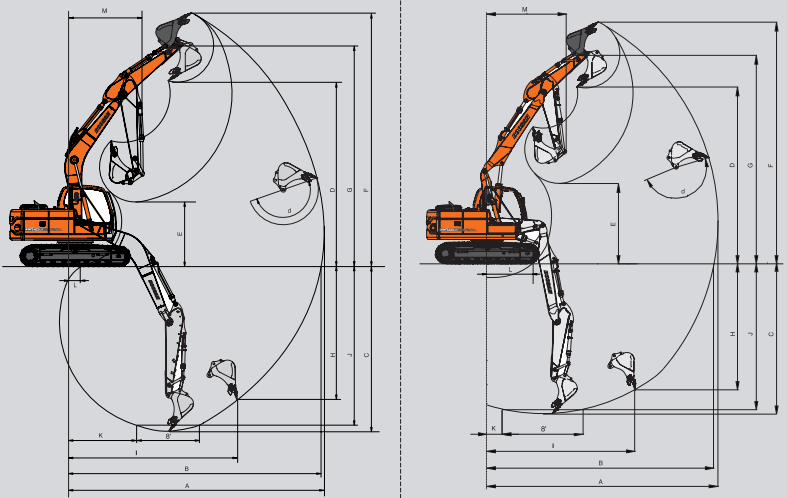



# Lifting capacity

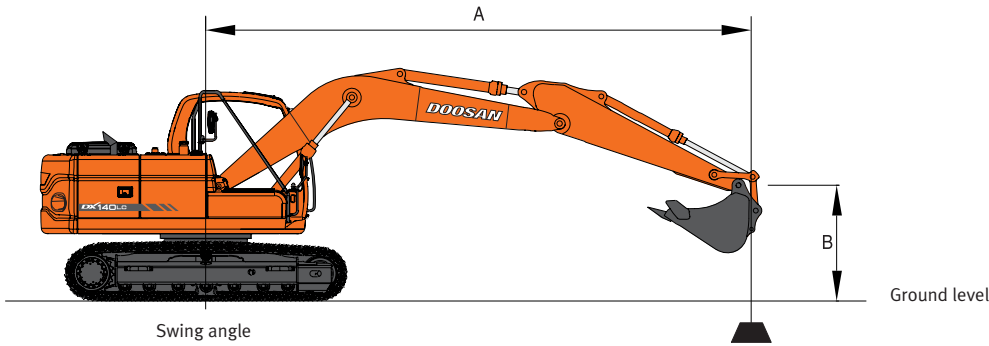

**DX140LC**

## ONE-PIECE BOOM

**Standard — Boom: 4.600 mm - Arm: 2.500 mm – Bucket: SAE 0,51 m<sup>3</sup> (CECE 0,45 m<sup>3</sup>), weight: 418 kg - Shoe: 600 mm**

**Units: 1.000 kg**

A (m)	2		3		4		5		6		Max. Reach		A(m)
7					*3,73	*3,73					*2,88	*2,88	4,24
6					*3,39	*3,39	*3,59	2,92			*2,45	*2,45	5,32
5					*3,61	*3,61	*3,72	2,94	*2,57	2,11	*2,25	2,08	6,04
4			*4,25	*4,25	*4,31	4,22	*4,05	2,92	3,42	2,13	*2,17	1,81	6,53
3					*5,38	4,11	*4,61	2,87	3,40	2,11	*2,16	1,66	6,83
2					*6,57	3,99	4,55	2,80	3,37	2,08	*2,20	1,59	6,98
1					6,52	3,88	4,48	2,75	3,33	2,05	*2,29	1,58	6,97
o (ground)					6,45	3,82	4,44	2,70	3,31	2,03	*2,45	1,64	6,82
-1			*6,07	6,04	6,42	3,79	4,41	2,68	3,30	2,02	*2,71	1,77	6,51
-2	*5,42	*5,42	*9,89	6,08	6,43	3,80	4,42	2,69	3,31	2,03	*3,13	2,03	6,01
-3	*9,35	*9,35	*9,47	6,15	6,47	3,84	4,46	2,72			4,15	2,54	5,24
-4			*7,27	6,27	*5,01	3,94					*4,55	3,74	4,14
-5											*2,88	*2,88	4,24

**Option — Boom: 4.600 mm - Arm: 2.100 mm – Bucket: SAE 0,51 m<sup>3</sup> (CECE 0,45 m<sup>3</sup>), weight: 418 kg - Shoe: 600 mm**

**Units: 1.000 kg**

A (m)	2		3		4		5		6		Max. Reach		A(m)
7											*4,36	*4,36	3,53
6					*3,99	*3,99					*3,60	3,10	4,78
5					*4,13	*4,13	*4,16	2,91			*3,30	2,39	5,57
4			*5,68	*5,68	*4,83	4,19	*4,43	2,90	3,40	2,11	*3,19	2,04	6,10
3					*5,90	4,09	4,61	2,86	3,39	2,11	3,01	1,86	6,42
2					6,63	3,98	4,55	2,81	3,37	2,09	2,88	1,77	6,58
1					6,53	3,89	4,50	2,76	3,34	2,06	2,87	1,77	6,57
o (ground)					6,48	3,84	4,46	2,73	3,32	2,05	2,99	1,83	6,41
-1			*6,58	6,11	6,46	3,83	4,45	2,71	3,32	2,04	3,25	2,00	6,08
-2	*6,47	*6,47	*10,21	6,16	6,48	3,85	4,46	2,73			3,79	2,33	5,54
-3	*11,75	*11,75	*8,78	6,24	6,54	3,90					4,94	3,02	4,73

**Option — Boom: 4.600 mm - Arm: 3.000 mm – Bucket: SAE 0,51 m<sup>3</sup> (CECE 0,45 m<sup>3</sup>), weight: 418 kg - Shoe: 600 mm**

**Units: 1.000 kg**

A (m)	2		3		4		5		6		7		Max. Reach		A(m)
7													*2,44	*2,44	4,93
6							*3,18	3,06					*2,20	*2,20	5,88
5							*3,24	3,06	*3,20	2,24			*2,09	1,90	6,54
4					*3,61	*3,61	*3,62	3,03	3,53	2,23			*2,06	1,69	6,99
3			*5,76	*5,76	*4,74	4,24	*4,21	2,97	3,50	2,20	2,70	1,68	*2,08	1,56	7,28
2					*5,99	4,10	4,64	2,89	3,45	2,16	2,68	1,67	*2,14	1,50	7,41
1					6,61	3,96	4,56	2,82	3,41	2,12	2,66	1,65	*2,25	1,49	7,41
o (ground)			*5,12	*5,12	6,51	3,87	4,50	2,76	3,37	2,09	2,64	1,63	*2,43	1,53	7,27
-1			*6,60	6,04	6,45	3,82	4,46	2,73	3,35	2,07			2,65	1,63	6,98
-2	*5,23	*5,23	*9,26	6,05	6,44	3,82	4,45	2,72	3,35	2,06			2,95	1,83	6,52
-3	*8,09	*8,09	*10,28	6,11	6,47	3,84	4,47	2,74					3,51	2,18	5,85
-4	*12,22	*12,22	*8,69	6,21	*6,48	3,91							*4,70	2,91	4,88

1. The nominal forces are based on the SAE J1097 standard.

2. The load point is the hook at the rear of the bucket.

3. \* = The nominal loads are based on hydraulic capacity.

4. The nominal loads do not exceed 87% of the hydraulic capacity or 75% of the capacity of the swing.

: Nominal force

: Nominal force at the side or 360°



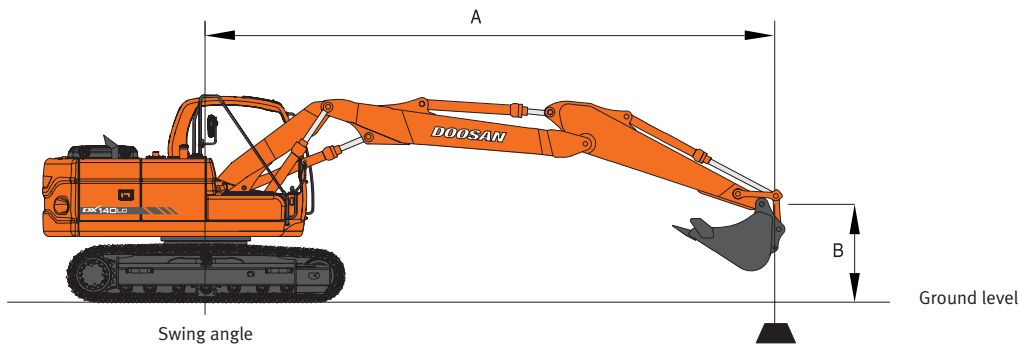

## TWO-PIECE BOOM

Option — Boom: 4.980 mm - Arm: 2.100 mm – Bucket: SAE 0,51 m<sup>3</sup> (CECE 0,45 m<sup>3</sup>), weight: 418 kg - Shoe: 600 mm

Units: 1.000 kg

B (m)	A (m)		2		3		4		5		6		Max. Reach		
	⏏	⏏	⏏	⏏	⏏	⏏	⏏	⏏	⏏	⏏	⏏	⏏	⏏	A(m)	
7			*3,23	*3,23									*3,63	*3,63	4,29
6			*2,86	*2,86	*3,25	2,92							*3,60	2,54	5,36
5			*3,23	*3,23	*3,26	2,93	3,41	2,09					*3,31	2,03	6,07
4			*4,08	*4,08	*3,67	2,89	3,42	2,11					2,90	1,76	6,56
3					*4,29	2,82	3,39	2,08					2,68	1,61	6,86
2					4,52	2,74	3,35	2,04	2,57	1,54			2,57	1,54	7,00
1					4,45	2,68	3,31	2,01	2,56	1,53			2,56	1,53	7,00
o (ground)			6,38	3,71	4,40	2,64	3,28	1,98					2,65	1,59	6,85
-1			6,37	3,71	4,38	2,62	3,27	1,97					2,86	1,72	6,54
-2	*7,39	5,99	6,40	3,73	4,39	2,63	3,30	1,99					3,26	1,97	6,05

Option — Boom: 4.980 mm - Arm: 2.500 mm – Bucket: SAE 0,51 m<sup>3</sup> (CECE 0,45 m<sup>3</sup>), weight: 418 kg - Shoe: 600 mm

Units: 1.000 kg

B (m)	A (m)		3		4		5		6		7		Max. Reach		
	⏏	⏏	⏏	⏏	⏏	⏏	⏏	⏏	⏏	⏏	⏏	⏏	⏏	A(m)	
8													*3,50	*3,50	3,35
7													*3,09	3,01	4,86
6					*2,76	*2,76							*2,68	2,20	5,83
5			*2,74	*2,74	*2,88	*2,88	*3,08	2,13					*2,47	1,81	6,49
4	*4,10	*4,10	*3,56	*3,56	*3,31	2,91	*3,24	2,12					*2,37	1,58	6,95
3			*4,71	4,06	*3,94	2,83	3,40	2,08	2,60	1,57			*2,33	1,46	7,23
2			*5,97	3,89	4,53	2,75	3,35	2,04	2,58	1,55			*2,35	1,40	7,37
1			6,44	3,76	4,44	2,67	3,30	1,99	2,56	1,53			2,35	1,39	7,36
o (ground)			6,35	3,69	4,38	2,62	3,27	1,96	2,54	1,51			2,42	1,43	7,22
-1	*3,25	*3,25	6,32	3,66	4,35	2,59	3,25	1,94					2,59	1,54	6,93
-2	*6,40	5,90	6,34	3,67	4,35	2,59	3,25	1,95					2,91	1,74	6,47
-3			6,39	3,72	4,39	2,62							3,88	2,33	5,40



# Standard and optional equipment

## \* Standard equipment

### • Hydraulic system

- Boom and arm flow regeneration
- Boom and arm safety valves
- Swing anti-rebound valves
- Spare ports (valve)
- One touch power boost
- Hydraulic piping for breaker

### • Cab & interior

- Cab mounted on viscous support
- All weather sound suppressed type cab
- Air conditioning with climat control
- Adjustable suspension seat with adjustable head rest and arm rests
- Sliding front window removable in two parts
- Room light
- Intermittent windshield wiper
- Cigarette lighter and ashtray
- Cup holder
- Hot & cool box
- LCD color monitor
- Fuel control dial
- Remote radio control on console
- Loudspeakers and connections for radio
- 12V power outlet
- PC interface port for Diagnostics
- Hydraulic control levers with 3 switches
- Sun roof
- Sun visor
- Rainshield

### • Safety

- Large handrail and steps
- Punched metal anti-slip plates
- Seatbelt
- Hydraulic safety lock lever
- Safety glass windows
- Hammer for emergency escape
- Side mirrors
- Emergency engine stop (switch)
- Overload warning device

### • Undercarriage

- Hydraulic track tension adjuster
- Track guards
- Greased and sealed track links

### • Other

- Two-stage air cleaner with one safety element
- Dust screen for radiators
- Engine overheat prevention system
- Engine restart prevention system
- Self-diagnostic system
- Alternator 24V, 60A
- Horn
- Halogen working lights
  - Chassis mounted 2
  - Boom mounted 2
- Double fuel filter
- Fuel tank filling pump

## \* Optional equipment

Some of these optional equipments may be standard in some markets. Some of these optional equipments cannot be available on some markets. You must check with the local DOOSAN dealer to know about the availability or to release the adaptation following the needs of the application.

### • Safety

- Cabin Top/Front guard (ISO 10262, standard FOGS)
- Travel alarm
- Swing alarm
- Rotating beacon

### • Cab & interior

- Heated air suspension seat
- Radio / CD
- Radio / CD / MP3

### • Undercarriage

- Triple grouser shoes 500, 700 mm
- Dozer blade

### • Other

- Hydraulic piping for crusher
- Hydraulic piping for quick coupler
- Hydraulic piping for clamshell
- Hydraulic piping for tilting and rotating
- Additional filter for breaker piping
- Lower cabin windshield wiper
- Fuel heater
- Light Pack (4 front & 2 rear cabin lights, telescopic beacon, 80Ah alternator)
- Video system with color LCD and o Lux camera
- Upper guard for front glass
- Lower guard for front glass
- Centralize greasing system

**DOOSAN Infracore Europe S.A.**

1<sup>st</sup>, rue Achille Degrâce  
7080 Frameries, Belgium  
Tel : +32-65-61 32 30 • Fax : +32-65-67 73 38

**DOOSAN Infracore France SA**

Buroplus 2  
Parc d'Activités de La Clef St Pierre  
Avenue Jean d'Alembert, bâtiment n° 2  
78990 Elancourt, France  
Tel : +33-1-30 16 21 41 • Fax : +33-1-30 16 21 44

**DOOSAN Infracore U.K., Ltd.**

Doosan House, Unit 6, 3 Heol-Y-Gamlas, Parc Nantgarw,  
Nantgarw, Cardiff CF15 7QU, U.K.  
Tel : +44-1443-84-2273 • Fax : +44-1443-84-1933

**DOOSAN Infracore Germany GmbH**

Heinrich-von-Stephan-Str. 2  
D-40764, Langenfeld, Germany  
Tel : +49-2173-2035212 • Fax : +49-2173-2035219

**Head Office**

Doosan Tower 26<sup>th</sup> FL. 18-12, Euljiro-6Ga,  
Jung-Gu, Seoul, Korea 100-730  
Tel : +82-2-3389-8114 • Fax : +82-2-3389-8117

[www.doosaneurope.com](http://www.doosaneurope.com)

